

SCT Weight Transmitter

10 Series

Installation & Operator's Manual



RICE LAKE[®]
WEIGHING SYSTEMS

To be the best by every measure[®]

131129 Rev B

Contents

1.0 Introduction.....	1
1.1 Safety	1
1.1.1 Safety Symbol Definitions:	1
1.1.2 Safety Precautions.	1
1.1.3 Equipment Recommendations	2
1.1.4 Correct Installation Of Weighing Instruments	2
1.1.5 Correct Installation Of The Load Cells	2
1.2 Load Cells.	3
1.2.1 Load Cell Input Test (Quick Access)	3
1.2.2 Load Cell Testing.	4
1.3 Specifications	4
1.4 Electrical Connections	6
1.5 LED and Key Functions	7
1.6 Instrument Commissioning	8
1.6.1 If The Instrument Has Not Been Calibrated	8
2.0 Configuration	9
2.1 Calibration	11
2.1.1 Theoretical Calibration	14
2.1.2 Maximum Capacity (NASS)	14
2.1.3 Zero Setting	15
2.1.4 Zero Value Manual Entry	15
2.1.5 Weight (Span) Calibration (With Test Weights)	16
2.1.6 Setting Units of Measure	17
2.1.7 Display Coefficient	17
2.2 Filter On The Weight	18
2.3 Zero Parameters.	20
2.4 Analog Output	21
2.4.1 Soldered Jumper.	22
2.4.2 Analog Output Type Scale Corrections	22
2.5 Serial Communication Settings.	23
2.5.1 RS-485 Serial Communication	25
2.6 Outputs And Inputs Configuration	26
2.7 Test	28
2.8 Setpoints Programming.	29
2.9 Reserved For The Installer.	30
2.9.1 Default Scale	30
2.9.2 Program Selection - Reverse:	30



Technical training seminars are available through Rice Lake Weighing Systems. Course descriptions and dates can be viewed at www.ricelake.com/training or obtained by calling 715-234-9171 and asking for the training department.

© Rice Lake Weighing Systems. All rights reserved. Printed in the United States of America.
Specifications subject to change without notice.
Rice Lake Weighing Systems is an ISO 9001 registered company.
March 17, 2015

2.9.3 Keypad Or Display Locking	31
3.0 Operation.....	32
3.1 Semi-Automatic Tare (Net/Gross)	32
3.2 Preset Tare (Subtractive Tare Device)	32
3.3 Semi-Automatic Zero (Weight Zero-setting For Small Variations).	33
3.4 Peak	33
3.5 Alarms.	33
3.6 Modbus-RTU Protocol.	34
3.7 ASCII Bidirectional Protocol	41
3.8 Fast Continuous Transmission Protocol.	46
3.9 Continuous Transmission Protocol To Remote Displays.	47
3.10 Communication Examples.	48
SCT Weight Transmitter Limited Warranty	51
For More Information	53



Rice Lake continually offers web-based video training on a growing selection of product-related topics at no cost. Visit www.ricelake.com/webinars.

1.0 Introduction

1.1 Safety

1.1.1 Safety Symbol Definitions:



Indicates a potentially hazardous situation that, if not avoided could result in death or serious injury, and includes hazards that are exposed when guards are removed.



Important

Indicates information about procedures that, if not observed, could result in damage to equipment or corruption to and loss of data.

1.1.2 Safety Precautions



Do not operate or work on this equipment unless you have read and understand the instructions and warnings in this manual. Contact any Rice Lake Weighing System dealer for replacement manuals. Proper care is your responsibility.



Failure to heed may result in serious injury or death.

Risk of electrical shock. No user serviceable parts. Refer to qualified service personnel for service.

The unit has no power switch, to completely remove D/C power from the unit, disconnect the D/C power cable from the main socket.

DO NOT allow minors (children) or inexperienced persons to operate this unit.

DO NOT operate without all shields and guards in place.

DO NOT use for purposes other than weighing applications.

DO NOT place fingers into slots or possible pinch points.

DO NOT use this product if any of the components are cracked.

DO NOT make alterations or modifications to the unit.

DO NOT remove or obscure warning labels.

DO NOT submerge.

1.1.3 Equipment Recommendations



Important *Failure to follow the installation recommendations will be considered a misuse of the equipment*

To Avoid Equipment Damage

- Keep away from heat sources and direct sunlight.
- Protect the instrument from rain.
- Do not wash, dip in water or spill liquid on the instrument.
- Do not use solvents to clean the instrument.
- Do not install in areas subject to explosion hazard.

1.1.4 Correct Installation Of Weighing Instruments

- The terminals indicated on the instrument's wiring diagram to be connected to earth must have the same potential as the scale structure (ground). If you are unable to ensure this condition, connect a ground wire between the instrument and the scale structure.
- The load cell cable must be run separately to the instrument input and not share a conduit with other cables. A shielded connection must be continuous without a splice.
- Use "RC" filters (quench-arcs) on the instrument-driven solenoid valve and remote control switch coils.
- Avoid electrical noise in the instrument panel; if inevitable, use special filters or sheet metal partitions to isolate.
- The panel installer must provide electrical protection for the instruments (fuses, door lock switch, etc.).
- It is advisable to leave equipment always switched on to prevent the formation of condensation.
- Maximum Cable Lengths:
 - RS-485: 1000 meters with AWG24, shielded and twisted cables
 - RS-232: 15 meters for baud rates up to 19200

1.1.5 Correct Installation Of The Load Cells

Installing Load Cells:

The load cells must be placed on rigid, stable structures within .5% of plumb and level. It is important to use mounting modules for load cells to compensate for misalignment of the support surfaces.

Protection Of The Load Cell Cable:

Use water-proof sheaths and joints in order to protect the cables of the load cells.

Mechanical Restraints (pipes, etc.):

When pipes are present, we recommend the use of hoses, flexible couplings and rubber skirted joints. In case of rigid conduit and pipes, place the pipe support or anchor bracket as far as possible from the weighed structure (at a distance at least 40 times the diameter of the pipe).

Welding:

Avoid welding with the load cells already installed. If this cannot be avoided, place the welder ground clamp close to the required welding point to prevent sending current through the load cell body.

Windy Conditions - Shocks - Vibrations:

The use of weigh modules is strongly recommended for all load cells to compensate for misalignment of the support surfaces. The system designer must ensure that the scale is protected against lateral shifting and tipping relating to shocks and vibration, windy conditions, seismic conditions and stability of the support structure.

Grounding The Weighed Structure:

By means of a 10ga solid or braided wire or braided grounding strap, connect the load cell upper support plate with the lower support plate, then connect all the lower plates to a single earth ground. Once installed electrostatic charges accumulated are discharged to the ground without going through or damaging the load cells. Failure to implement a proper grounding system might not affect the operation of the weighing system; this, however, does not rule out the possibility that the load cells and connected instrument may become damaged by ESD. It is forbidden to ensure grounding system continuity by using metal parts contained in the weighed structure.(see Figure 1-1.)

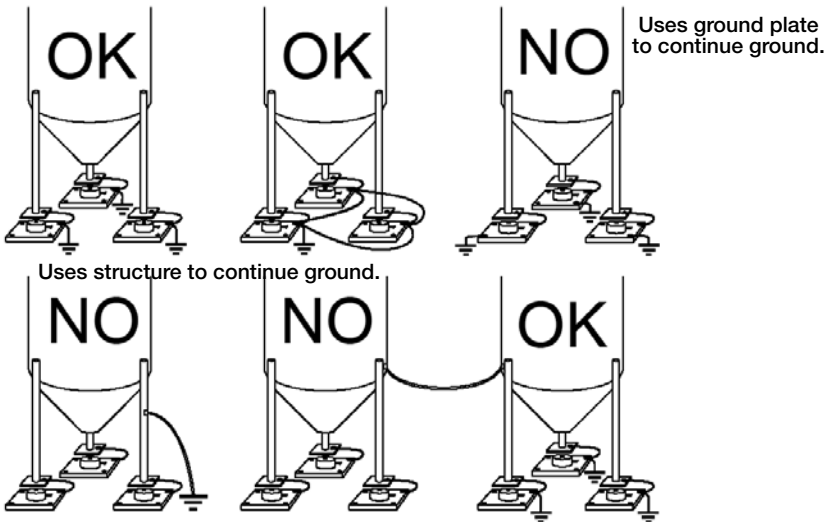





Figure 1-1. Installation Recommendations

1.2 Load Cells

1.2.1 Load Cell Input Test (Quick Access)

1. From the weight display, press  for 3 seconds.
2. The display will read NU-CEL. Press .
3. The response signal of the load cell is displayed, expressed in mV with four decimals. Press  three times to exit set-up mode.

1.2.2 Load Cell Testing

Load Cell Resistance Measurement (Use A Digital Multimeter):

- Disconnect the load cells from the instrument and check that there is no moisture in the load cell junction box caused by condensation or water infiltration. If so, drain the system or replace it if necessary.
- The value between the positive signal wire and the negative signal wire must be equal or similar to the one indicated in the load cell data sheet (output resistance).
- The value between the positive excitation wire and the negative excitation wire must be equal or similar to the one indicated in the load cell data sheet (input resistance).
- The insulation value between the shield and any other load cell wire and between any other load cell wire and the body of the load cell must be higher than 20 Mohm (mega ohms).

Load Cell Voltage Measurement (Use A Digital Multimeter):

- Remove weight of scale from load cell to be tested.
- Make sure that the excitation wires of the load cell connected to the instrument is 5 Vdc +/- 3%.
- Measure the millivolt signal between the positive and the negative signal wires by directly connecting them to the multi-meter, and make sure it reads between 0 and 0.5 mV (thousandths of a Volt).
- Apply load to the load cell and make sure that there is a signal increment.



Important *If one of the above conditions is not met, please contact the technical assistance service.*

1.3 Specifications

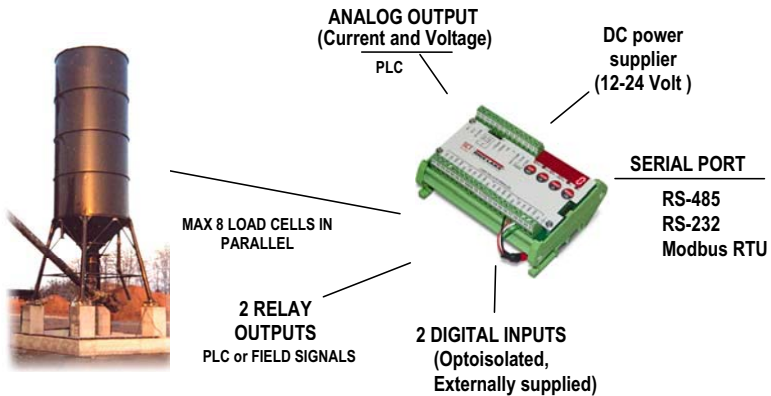

- Weight indicator and transmitter for Omega/DIN rail mounting suitable for back panel; space saving vertical shape. Six-digit semi alphanumeric display (18mm h), 7 segment. Four-key keyboard. Dimensions: 25x115x120 mm.
- Displays the gross weight; with an external contact capable of remote zeroing and gross/net switching.
- IP67 box version (dimensions: 170x140x95mm). Four fixing holes diameter 4mm (center distance 122x152mm).
- Peak weight function.

- Transmits the gross or net weight via opto-isolated analog output 16 bit, current 0-20mA, 4-20mA or voltage 0-10V, 0-5V ($\pm 0V$ / $\pm 5V$ by closing a soldered jumper).
- Transmits the gross or net weight via RS-485 serial port, by means of protocols:
 - Modbus RTU
 - ASCII bidirectional protocol
 - Continuous transmission

Power Supply And Consumption (VDC)	12 - 24 VDC (standard) \pm 10% ; 5 W
No. Of Load Cells In Parallel and Supply	max 8 (350 ohm) ; 5VDC/120mA
Linearity / Analog Output Linearity	< 0.01% F.S. ; < 0.01% F.S.
Thermal Drift / Analog Output Thermal Drift	< 0.0005 % F.S. / $^{\circ}$ C ; < 0.003 % F.S./ $^{\circ}$ C
A/D Converter	24 bit (16.000.000 points)
Max Divisions (With Measurement Range: \pm 10mv = Sens. 2mv/v)	\pm 999999
Measurement Range	\pm 19.5 mV
Max Sensitivity Of Usable Load Cells	\pm 3mV/V
Max Conversions Per Second	80 conversions/second
Display Range	- 999999 ; + 999999
No. of Decimals / Display Increments	0 - 4 / x 1 x 2 x 5 x 10 x 20 x 50 x 100
Digital Filter / Readings Per Second	0.080 – 7.5 sec / 5 - 80 Hz
Relay Logic Outputs	N.2 - max 24 VAC ; 60mA
Logic Inputs	N.2 - optoisolated 5 - 24 VDC PNP
Serial Ports	RS-485 (RS-232)
Baud Rate	2400, 4800, 9600, 19200, 38400, 115200
Humidity (Non Condensing)	85 %
Storage Temperature	- 30 $^{\circ}$ C + 80 $^{\circ}$ C
Working Temperature	- 20 $^{\circ}$ C + 60 $^{\circ}$ C
Optoisolated Analog Output 16 Bit - 65535 Divisions	0-20 mA; 4-20 mA (max 300 ohm); 0-10 VDC; 0-5 VDC; \pm 10 VDC; \pm 5 VDC (min 10 kohm).

Table 1-1. Technical Specifications

1.4 Electrical Connections

- It is recommended that the negative side of the power supply be grounded.
- It is possible to power up to eight 350 ohm load cells or sixteen 700 ohm load cells.
- Connect terminal “0 VDC” to the RS-485 common of the connected instruments in the event that these receive alternating current input or that they have an opto-isolated RS-485.
- In case of an RS-485 network with several devices it is recommended to activate the 120 ohm termination resistance on the two devices located at the ends of the network, see Section 2.5.1 on page 25.

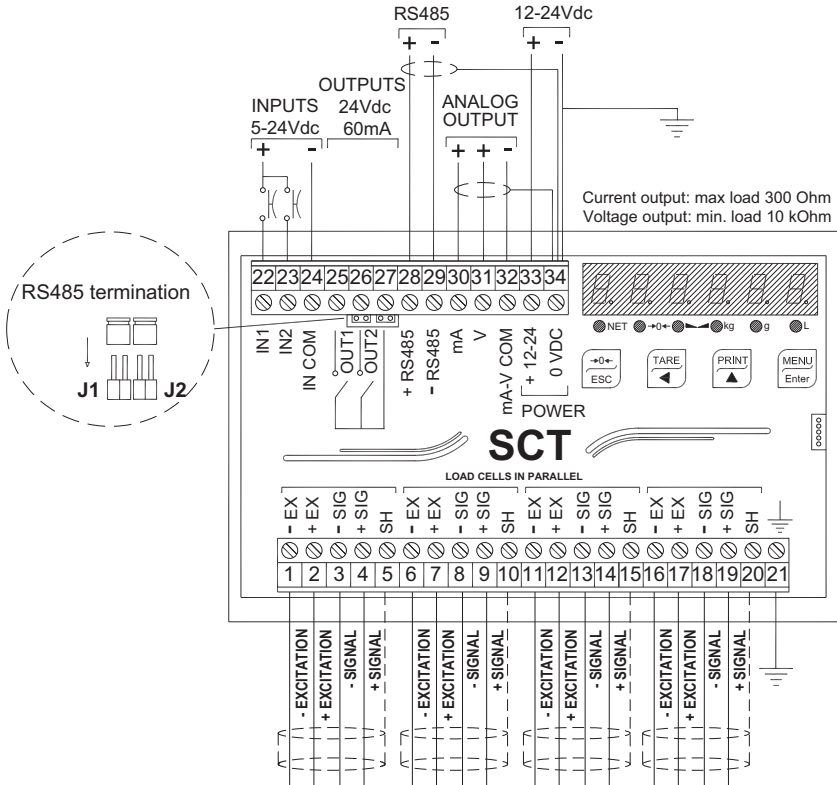

2 outputs: configurable setpoints or remote output management via protocol.



2 inputs (Default: **SEMI-AUTOMATIC ZERO input 1**; **NET/GROSS input 2**): settable to have the following functions: **SEMI-AUTOMATIC ZERO**, **NET/GROSS**, **PEAK**, or **REMOTE CONTROL** (see Section 2.6 on page 26).

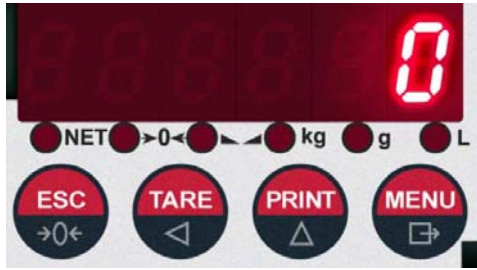











1.5 LED and Key Functions



LED	Main function	Secondary function *
NET	Net weight LED: net weight display (semi-automatic tare or preset tare)	LED lit: input 1 closed
→0←	Zero LED (deviation from zero not more than +/- 0.25 divisions)	LED lit: input 2 closed
▲▲	Stability LED	LED lit: output 1 closed
kg	Unit of measure: kg	LED lit: output 2 closed
g	Unit of measure: g	No meaning
L	Unit of measure:lb	No meaning

* To activate the secondary LED function, during weight display press and hold

, then press .

Key	Short press	Long press (3 sec)	Into menus
 Escape		Zero Setting	Cancel or return to previous menu
 Scroll/ Backspace	Captures Tare Gross → Net	Removes Tare Net → Gross	Select figure to be modified or return to previous menu item
 Next/ Data Entry		mV load cell test	Modify selected figure or go to next menu item
 Enter	Setting setpoints and hysteresis		Confirm or enter in submenu
 + 	Setting general parameters (press and hold  then press  to enter set-up menu.		
 + 	Setting preset tare (press and hold  then press  to enter set-up menu.		

 **Note** The LEDs light up in sequence to indicate that a setting and not a weight is being viewed.

1.6 Instrument Commissioning

1. Plug power cord in to outlet to turn on indicator, the display shows in sequence:
 - “SU” followed by the software code (e.g.: SU S);
 - - “r” followed by the software version (e.g.: r 1.04.01);
 - - “HU” followed by the hardware code (e.g.: HU 104);
 - - the serial number (e.g.:1005 15);
2. Check that the display shows the weight and that when loading the load cells there is an increase in weight.
3. If there is not, check and verify the connections and correct positioning of the load cells.



Note *If instrument has NOT been calibrated complete Section 2.1 before proceeding to next step.*

4. Reset to zero. See Section 2.1.3 on page 15.
5. Check the calibration with test weights and correct the indicated weight if necessary. See Section 2.1.5 on page 16.
6. If you use the analog output, set the desired analog output type and the full scale value. See Section 2.4 on page 21.
7. If you use serial communication, set the related parameters. See Section 2.5 on page 23.
8. If setpoints are used, set the required weight values and the relevant parameters. See Section 2.8 on page 29 and Section 2.6 on page 26.

1.6.1 If The Instrument Has Not Been Calibrated

Missing plant system identification tag, proceed with calibration:

1. If load cells data are unknown, follow the procedure in Section 2.1.5 on page 16.
2. Enter the rated data of load cells following the procedure given in Section 2.1.1 on page 14.

2.0 Configuration

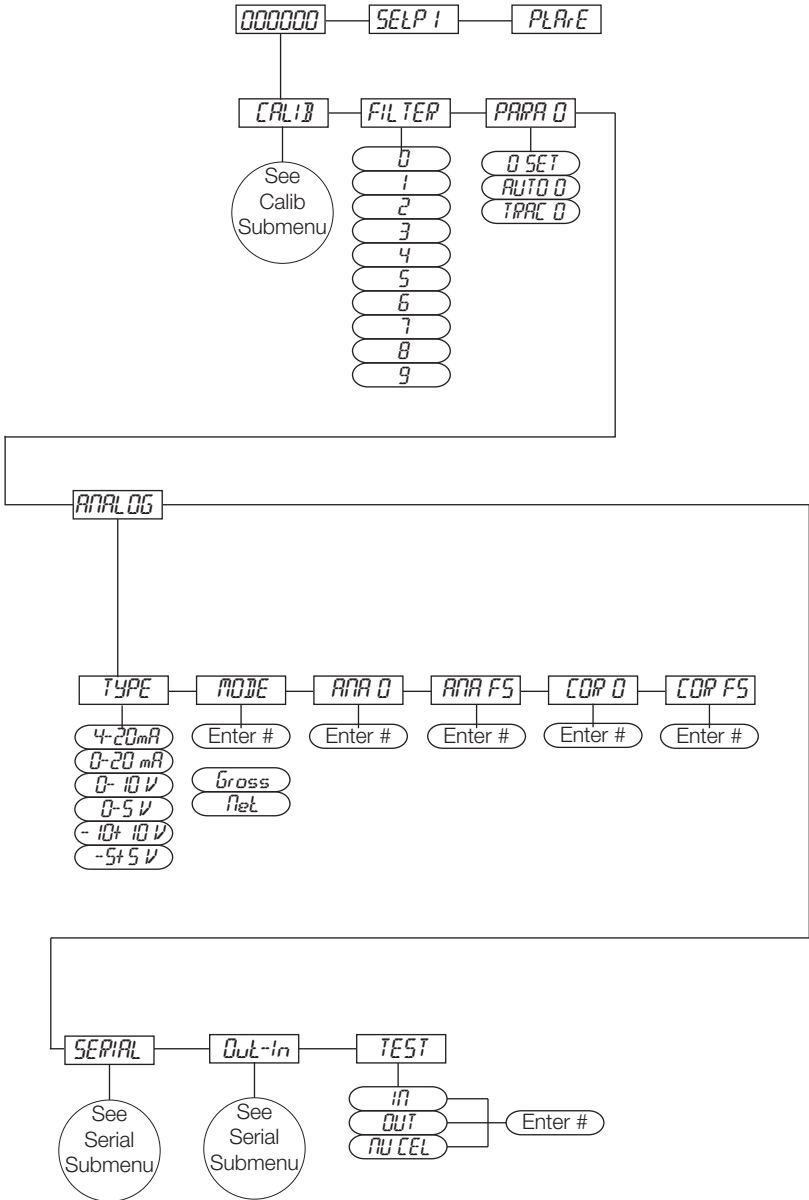

Figure 2-1. Scale Menu Structure

Parameter	Choices	Description
CHARL b	FS-LED SEnS I b dl Ul S nASS ZER0 I nP 0 WEIGHt Unit COEFF	See Section 2.1Section 2.1 on page 11.
Filter	0-9 4	Allows a stable weight display to be obtained. See Section 2.2 on page 18.
PARA 0	0 SEt RUL0 0 t-R0 0	See Section 2.3 on page 20.
ANALOG	TYPE n0dE AN0 AN0 FS C0r 0 C0r FS	See Section 2.4 on page 21.
SERIAL	rS-485 bAUd Addr dELAY PARI tY StOP	See Section 2.5 on page 23.
OUT-1 n	OUT 1 OUT 2 In 1 In 2	See Section 2.6 on page 26.
tEst	In OUT ANALOG nU-CCL	See Section 2.7 on page 28.
* - indicates default value.		

Table 2-1. Scale Menu

2.1 Calibration

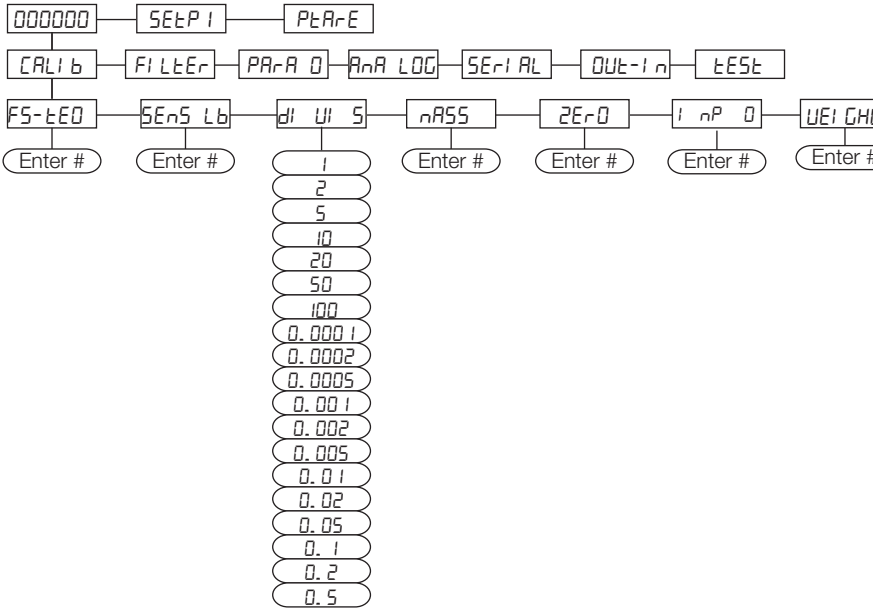

Figure 2-2. Calibration Menu Structure

Parameter	Choices	Description
FS-tEd	Enter # deno *	<p>System Full Scale is determined by multiplying one load cell capacity by the number of load cells used. Example of system full scale value calculation:</p> <p style="text-align: center;">4 cells of 1000kg ----> FULL SCALE = 1000 X 4 = 4000</p> <p> Note <i>The instrument is supplied with a theoretical full scale value deno corresponding to 10000. To restore factory values, set 0 as full scale.</i></p>
SEnS Lb	Enter # 0.50000 to 7.00000 2.00000 *	<p>Sensitivity is a load cell rated parameter expressed in mV/V. Set the average sensitivity value indicated on the load cells. I</p> <p>Example of 4-cell system with sensitivity 2.00100, 2.00150, 2.00200, 2.00250; enter 2.00175, calculated as (2.00100 + 2.00150 + 2.00200 + 2.00250) / 4.</p>

Table 2-2. Calibration Menu

Parameter	Choices	Description
dI U 5	1 2 * 5 10 20 50 100 0.0001 0.0002 0.0005 0.001 0.002 0.005 0.01 0.02 0.05 0.1 0.2 0.5	Division (resolution) - the weight increment (display division size) that the scale counts by. Selections are: 0.0001 and 100 with x1 x2 x5 x10 increments.
nR55	Enter # 0 * to max full scale	Maximum capacity (Live Load/Product) that can be displayed. When the weight exceeds this value by 9 divisions, the display will go to dashes, indicating overload. Setting this value to 0 will disable the over capacity function.
ZEr 0	0	Used to capture the deadload of the scale system. With the scale empty, the displayed value can be zeroed off. This menu may also be accessed directly from the weighing mode to compensate for zero changes or variations. Press  to display the accumulated weight that has been zeroed off.
i nP 0	Enter # 0 to 999999 0 *	Estimated dead load value of the scale when a scale contains product that cannot be removed. The value entered is the dead load. This value will be replaced if the zero function is performed later.

Table 2-2. Calibration Menu

Parameter	Choices	Description
WEIGHT	Enter # 0 *	<p>Weight (Span) Calibration - after the Theoretical Calibration has been completed and zero is set, the calibration can be adjusted with actual test weights by changing the displayed value in this parameter.</p> <p> Note <i>If changes are made to the theoretical Full Scale (FS-LEW), the Sensitivity (SENSI b) or Divisions (d/ W/ S) parameters, the weight (span) calibration is canceled and the theoretical calibration is initiated and applied.</i></p> <p><i>If the theoretical full scale (FS-LEW) and the capacity full scale (CAPSS) are equal in weight (span) calibration (WEIGHT), then the calibration currently in use is theoretical; if they are different, the calibration in use is the weight (span) calibration based on calibration weights.</i></p> <p><i>If changes are made to the theoretical full scale (FS-LEW), the capacity full scale (CAPSS) or divisions (d/ W/ S) parameters, all the system's parameters containing a weight value will be set to default values (setpoints, hysteresis, etc.).</i></p>
UNIT	G t Lb nEUton LI tRE bAr Atn PI ECE nEU-n HI LQ-n QTHEr HI LQG	<p>Unit of Measure - select to determine what unit of measure is displayed and printed.</p> <p>See Section 2.1.6 on page 17 for description of units.</p>
COEFF	Enter # 0-99.9999 0 *	<p>Multiplier Value entered will display an alternative unit of measure if the digital input is set for COEFF and is in a closed state.</p>
* - indicates default value.		

Table 2-2. Calibration Menu



Note

To calibrate the instrument, the Section 2.1.1 on page 14 must be completed first. After Theoretical Calibration is set, the scale can be set with actual weights (see Section 2.1.5 on page 16).





















2.1.1 Theoretical Calibration

This function allows load cell rated values to be set.

To perform the theoretical calibration set $F5-tEd$, $SEn5$ LB and dI U 5 in sequence:



Note When entering a menu, the LED's will begin scrolling, when selection is made and confirmed the LED's will be off.

1. Press and hold , then press . LR LB will be displayed.
2. Press , $F5-tEd$ is displayed. Press .
3. Press  or  until total load cell capacity (system full scale) is displayed, press .
4. Press  or  until $SEn5$ LB is displayed, press .
5. Press  or  until desired load cell mV/V is displayed, press .
6. Press  or  until dI U 5 is displayed, press .
7. Press  or  until desired display division size is displayed, press .
8. This complete the Theoretical Calibration, press  twice to exit set-up menu or continue to Section 2.1.2.



Note By modifying the theoretical full scale, the sensitivity or divisions, the weight (span) calibration is canceled and the theoretical calibration only is considered valid.









If the theoretical full scale and the recalculated full scale in weight (span) calibration (see Section 2.1.5) are equal, this means that the calibration currently in use is theoretical; if they are different, the calibration in use is the weight (span) calibration based on test weights.

By modifying the theoretical full scale, the sensitivity or divisions and all the system's parameters containing a weight value will be set to default values (setpoints, hysteresis, etc.).

2.1.2 Maximum Capacity (NASS)

Maximum capacity (live load/product) that can be displayed. When the weight exceeds this value by 9 divisions the following is displayed '-----', indicating overload. To disable this function, set to 0.

1. Press and hold , then press . LR LB will be displayed.









2. Press , *F5-LE0* is displayed.
3. Press  or  until *nR55* is displayed, press . LED's will begin scrolling.
4. Press  or  until desired capacity is displayed, press .
5. Press  twice to exit set-up menu.

2.1.3 Zero Setting

Perform this procedure after having set the Section 2.1.1 on page 14.



This menu may also be accessed directly from the weight display, press and hold  for 3 seconds.

1. Press and hold , then press . *LRLi b* will be displayed.
2. Press , *F5-LE0* is displayed.
3. Press  or  until *ZER0* is displayed, press .
4. The weight value to be set to zero is displayed. In this phase all of the LEDs are flashing. Press , the weight is set to zero (the value is stored to the permanent memory).
5. Press  twice to exit set-up menu.













Press  to display the accumulated deadload that has been zeroed off by the instrument, displaying the sum of all of the previous zero settings.

2.1.4 Zero Value Manual Entry













Important *Perform this procedure only if it is not possible to reset the weighed structure tare, for example because it contains product that can not be unloaded.*

Set in this parameter the estimated zero value.

1. Press and hold , then press . *LRLi b* will be displayed.
2. Press , *F5-LE0* is displayed.
3. Press  or  until *LRP 0* is displayed, press . LED's will begin scrolling.
4. Press  or  until desired dead load is displayed, press .
5. Press  twice to exit set-up menu.

2.1.5 Weight (Span) Calibration (With Test Weights)

After performing Section 2.1.1 on page 14 and Section 2.1.3 on page 15, this function allows correct calibration to be done using test weights of known value, if necessary, any deviations of the indicated value from the correct value to be corrected.

1. Load the test weight onto the scale, use as high a percentage of the maximum quantity to be weighed as possible.
2. Press and hold , then press . *CALL b* will be displayed.
3. Press , *F5-LED* is displayed.
4. Press  or  until *UE! GHE* is displayed, press .
5. The value of the weight currently on the system will be flashing on the display. All the LEDs are off. (If adjustment is not required, skip to step 8.)
6. Adjust the value on display to match weight loaded on the scale if necessary, by pressing  or . The LED's will begin scrolling.
7. Press , the new set weight will appear with all the LEDs flashing.
8. Press  again, *UE! GHE* will be displayed.
9. Press  twice to exit set-up menu.

Example:

For a system of maximum capacity of 1000 kg and 1 kg division, two test weights are available, one 500 kg and one 300 kg. Load both weights onto the system and correct the indicated weight to 800. Now remove the 300 kg weight, the system must show 500; remove the 500 kg weight, too; the system must read zero. If this does not happen, it means that there is a mechanical problem affecting the system linearity.



Important

Identify and correct any mechanical problems before repeating the procedure.



Note

If theoretical full scale and recalculated full scale in weight (span) calibration are equal, it means that the theoretical calibration is currently in use; otherwise, the weight (span) calibration based on test weights is in use.

If the correction made changes the previous full scale for more than 20%, all the parameters with settable weight values are reset to default values.











Linearization Option On Max 5 Points:

It is possible to perform a linearization of the weight repeating the above-described procedure up to a maximum of five points, using five different test weights.

The procedure ends by pressing  or after entering the fifth value; at this point it will no longer be possible to change the calibration value, but only to perform a new weight (span) calibration. To perform a new calibration, should return to the weight display and then re-entering into the calibration menu.

By pressing  after having confirmed the test weight that has been set, full scale appears, recalculated according to the value of the maximum test weight entered and making reference to the cell sensitivity set in the theoretical calibration (5EN5¹ b).

2.1.6 Setting Units of Measure

1. Press and hold , then press . *CALL b* will be displayed.
2. Press , *F5-EE0* is displayed.
3. Press  or  until *Unit E* is displayed, press .
4. Press  or  until desired unit is displayed, press .
5. Press  twice to exit set-up menu.

<i>Hi LOG</i>	kilograms	<i>bAr</i>	bar*
<i>G</i>	grams	<i>Atn</i>	atmospheres*
<i>t</i>	tons	<i>Pi ECE</i>	pieces*
<i>Lb</i>	pounds*	<i>nEU-n</i>	newton metres*
<i>nEUton</i>	newton*	<i>Hi LQ-n</i>	kikgram metres*
<i>Li tRE</i>	litres*	<i>QtHEr</i>	other generic units of measure not included in list*

* Indicates it is possible to set the display coefficient. To use COEFF it is necessary to enable it, closing the COEFF input. See Section 2.1.7 on page 17.













Note *If the print function is enabled, the symbol of the selected unit of measure will be printed after the measured value.*

2.1.7 Display Coefficient

By setting the coefficient the display is changed accordingly.

If one of the inputs is set to COEFF mode (see Section 2.6 on page 26) when the input is closed the value will be displayed modified according to the coefficient; when the input is opened the standard weight display will be restored.

1. Press and hold , then press . *CALL b* will be displayed.
2. Press , *F5-EE0* is displayed.
3. Press  or  until COEFF is displayed, press . LED's will begin scrolling.
4. Press  or  until desired number is displayed, press .
5. Press  twice to exit set-up menu.

HI LOG	kilograms	
G	grams	
t	tons	
Lb	pounds	Value set in COEFF will be multiplied by the weight value currently displayed
nEUton	newton	Value set in COEFF will be multiplied by the weight value currently displayed
Li t r E	litres	in COEFF set the specific weight in kg/l, assuming that the system is calibrated in kg
bAr	bar	Value set in COEFF will be multiplied by the weight value currently displayed
Atm	atmospheres	Value set in COEFF will be multiplied by the weight value currently displayed
Pi ECE	pieces	in COEFF set the weight of one piece
nEU-n	newton metres	Value set in COEFF will be multiplied by the weight value currently displayed
HI LOG-n	kikgram metres	Value set in COEFF will be multiplied by the weight value currently displayed
Other	other generic units of measure not included in list	Value set in COEFF will be multiplied by the weight value currently displayed

Table 2-3. Coefficient Value by Unit of Measure



Important

All other settings (setpoints, hysteresis, calibration ...) are expressed in weight value. If you want to convert them to the new unit of measurement, perform one of the following procedures for changing the system calibration.

The parameter must remain set to 1.0000.

Theoretical Calibration For Other Units Of Measure

Set in the parameter the F.SCALE value divided by the conversion coefficient from kg to the new unit of measure.

Example: The 4 load cells of 1000 kg are placed under a scale for oil, which has a specific gravity of 0.916 kg / l. Setting the F.SCALE = (4x1000) / 0916 = 4367, the system works in liters of oil. If you set the unit to liters, the system will display and print the symbol 'l' instead of 'kg'. See Section 2.1.6 on page 17.











Weight (Span) Calibration For Other Units Of Measure

Load a known quantity of product liters on the scale (equal to at least 50% of the maximum amount that you must weigh) and enter in the parameter UEI GHt, the product loaded value in liters. If you set the units to liters, the system will display and print the symbol 'l' instead of 'kg'. See Section 2.1.6 on page 17.

2.2 Filter On The Weight

The filtering selection is used to eliminate environment noise, and is typically a compromise between responsiveness and stability. The lower the number, the more responsive the display will be to weight changes. The filter is used to stabilize a weight as long as the variations are smaller than the corresponding "Response Time". The filter setting is dependent on the type of application and the required update rate.

Setting this parameter allows a stable weight display to be obtained. To increase the effect (weight more stable), increase the value.

1. Press and hold , then press . *FLTR* will be displayed.
2. Press  or  until *FILTER* is displayed, press . LED's will begin scrolling.
3. Press  or  until desired filter value is displayed, press .
4. The weight is displayed (all LED's will be flashing) and the displayed stability can be experimentally verified. Press .
5. If stability is not satisfactory, press , this returns indicator to *FILTER* option and the filter may be modified again until an optimum result is achieved.
6. Press  to exit set-up menu.



Note













The filter enables to stabilize a weight as long as its variations are smaller than the corresponding "Response Time". It is necessary to set this filter according to the type of application and to the full scale value set.

Filter Value	Response times [ms]	Display and serial port refresh frequency [Hz]
0	80	80
1	190	80
2	260	40
3	450	26
4*	900	13
5	1700	13
6	2500	13
7	4200	10
8	6000	10
9	7500	5

* indicates default value.

Table 2-4. Filter Settings

2.3 Zero Parameters

1. Press and hold , then press . `CALLb` will be displayed.
2. Press  or  until `PARA 0` is displayed, press .
- 2-1. Press  or  until desired parameter is displayed, press . The currently programmed value is displayed and LED's will be scrolling.
3. Press  or  until desired value is displayed, press .
4. Press  twice to exit set-up menu.

Parameter	Choices	Description
<code>0 SEt</code>	Enter # 0-max full scale 300 * Considered decimals: 300 - 30.0 - 3.00 - 0.300	Resettable Weight setting for small weight change. Indicates the maximum weight value resettable by external contact, keypad or serial protocol
<code>Aut 0</code>	Enter # 0 - max 20% of full scale 0 *	Automatic zero setting at power-on If when indicator is powered on the weight value is lower than the value set in this parameter and does not exceed the <code>0 SEt</code> value, the weight is reset. To disable this function set to 0.
<code>trAC 0</code>	nOnE * 1-5	Zero tracking When the zero weight value is stable and, after a second, it deviates from zero by a figure in divisions smaller or equal to the figure in divisions set in this parameter, the weight is set to zero. To disable this function, set to none Example: if the parameter <code>dI UI S</code> is set to 5 and <code>trAC 0</code> is set to 2, the weight will be automatically set to zero for variations smaller than or equal to 10 (<code>dI UI S x trAC 0</code>).
* - indicates default value.		

Table 2-5. Zero Parameters Settings

2.4 Analog Output

Parameter	Choices	Description
TYPE	4-20 mA * 0-20 mA 0-10 V 0-5 V -10 +10 V -5 +5 V	Selects the analog output type. See Section 2.4.1 on page 22 See Section 2.4.1 on page 22
mode	Enter # Gross Net	Select mode to be tracked, gross or net. If the net function is not active, the analog output varies according to gross weight.
AnA 0	Enter #	Set the weight value for the minimum analog output value.  Note <i>Only set a value different from zero to limit the analog output range.</i> <i>E.G.:: for a full scale value of 10000 kg, a 4 mA signal at 5000 kg is required, and 20 mA at 10000 kg, in this case, instead of zero, set 5000 kg.</i>
AnA FS	Enter #	Set the weight value for the maximum analog output value; it must correspond to the value set in the PLC program (default: calibration full scale). <i>E.g.: if using a 4-20 mA output and in the PLC program a 20 mA = 8000 kg is desired, set the parameter to 8000.</i>
CO- 0		Analog output correction to zero: if necessary adjust the analog output, allowing the PLC to indicate 0. The sign '-' can be set for the last digit on the left. <i>E.g.: For a 4-20 mA output and a minimum analog setting, the PLC or tester reads 4.1 mA. Set the parameter to 3.9 to obtain 4.0 on the PLC or tester. (See Section 2.4.2 on page 22)</i>
CO- FS		Full scale analog output correction: if necessary adjust the analog output, allowing the PLC to indicate the value set in the AnA FS parameter. <i>E.g. For a 4-20 mA output with the analog set to full scale and the PLC or tester reads 19.9 mA, set the parameter to 20.1 to obtain 20.0 on the PLC or tester. (See Section 2.4.2 on page 22)</i>
* - indicates default value.		

Table 2-6. Analog Output Menu

2.4.1 Soldered Jumper

For the output -10 +10 V and -5 +5 V the soldered jumper J7 must be closed:

- Remove the face plate of the instrument by removing the screws that attach it to the little columns on the printed circuit board.
- On the circuit board, locate the jumper J7, situated above the 3 and 4 terminals at about mid board.
- Scrape away the solder from the jumper bay, until the copper underneath is uncovered.
- Close the jumper short circuiting the bays, it is also recommended that a small piece of copper wire without insulation or a leg wire be used to facilitate the operation.

2.4.2 Analog Output Type Scale Corrections

Minimum and maximum values which can be set for the zero and full scale corrections

Analog Output Type	Minimum	Maximum
0-10 V	-0.150	10.200
0-5 V	-0.150	5.500
-10 +10 V	-10.300	10.200
-5 +5 V	-5.500	5.500
0-20 mA	-0.200	22.000
4-20 mA	-0.200	22.000



Note

The analog output may also be used in the opposite manner, i.e. the weight setting that corresponds to the analog zero may be greater than the weight set for the analog full scale. The analog output will increase towards full scale as the weight decreases; the analog output will decrease as the weight increases.

E.g.: analog output type having selected 0-10V

ANA 0 = 10000 ANA FS = 0

Weight = 0 kg analog output = 10 V

Weight = 5000 kg analog output = 5 V

Weight = 10000 kg analog output = 0 V

2.5 Serial Communication Settings

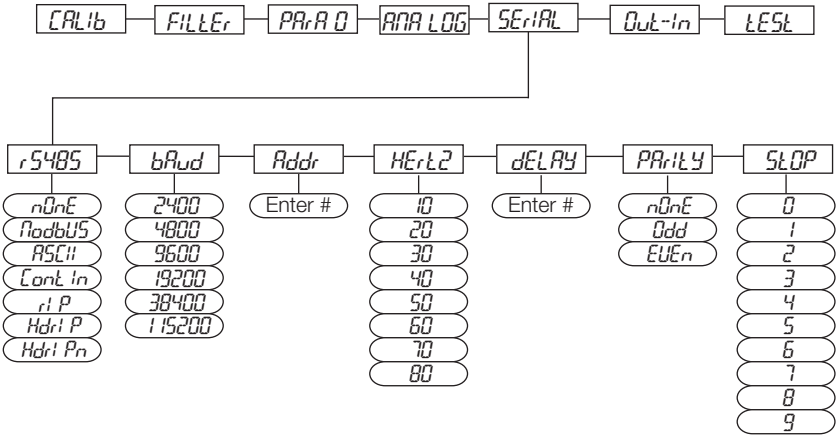

Figure 2-3. Serial Communications Menu Structure

According to the chosen protocol only the necessary settings will be displayed in sequence.

Parameter	Choices	Description
r5-485 (Communication Port)	nOnE *	Disables any type of communication (default).
	ModBUS	MODBUS-RTU protocol; possible addresses: from 1 to 99 (see Section 3.6)
	ASCII	ASCII bidirectional protocol; possible addresses: from 1 to 99 (see Section 3.7) NOdU6- NOdtd
	ContIn	Continuous weight transmission protocol (see Section 3.8), at the frequency set in HERTZ parameter (from 10 to 300). NOdt(set: PARITY=none, STOP=1) NOdtd(set: PARITY=none, STOP=1)
	rIP	Continuous weight transmission protocol, streams net and gross (see Section 3.9) (set: BAUD=9600,PARITY=none, STOP=1)
	HdrIP	Continuous weight transmission protocol, streams net and gross including decimal (see Section 3.9) (set: BAUD=9600,PARITY=none, STOP=1)

Table 2-7. Serial Communications Menu

Parameter	Choices	Description
r5-485 (cont)	Hdr Pn	Continuous weight transmission protocol (see Section 3.9) <i>When the remote display is set to gross weight:</i> - if the instrument displays the gross weight, the remote display shows the gross weight. - if the instrument shows the net weight the remote display shows the net weight alternated with the message "net"
bAud	2400 4800 9600 19200 38400 115200	Transmission speed.
Addr	1-99 1*	Instruments address
HErT2	10H2 20H2 30H2 40H2 50H2 60H2 70H2 80H2	Maximum Transmission Frequency - to be set when the CONTIN transmission protocol is selected. (see Table 2-4 on page 19) Max setting with min 2400 baud rate Max setting with min 4800 baud rate Max setting with min 9600 baud rate
dELAY	0-200 msec 0*	Delay in milliseconds which elapses before the instrument replies
PARITY	nOnE * EVEN odd	parity none even parity odd parity
STOP	1 * 2	Stop bit
* - indicates default value.		

Table 2-7. Serial Communications Menu

2.5.1 RS-485 Serial Communication

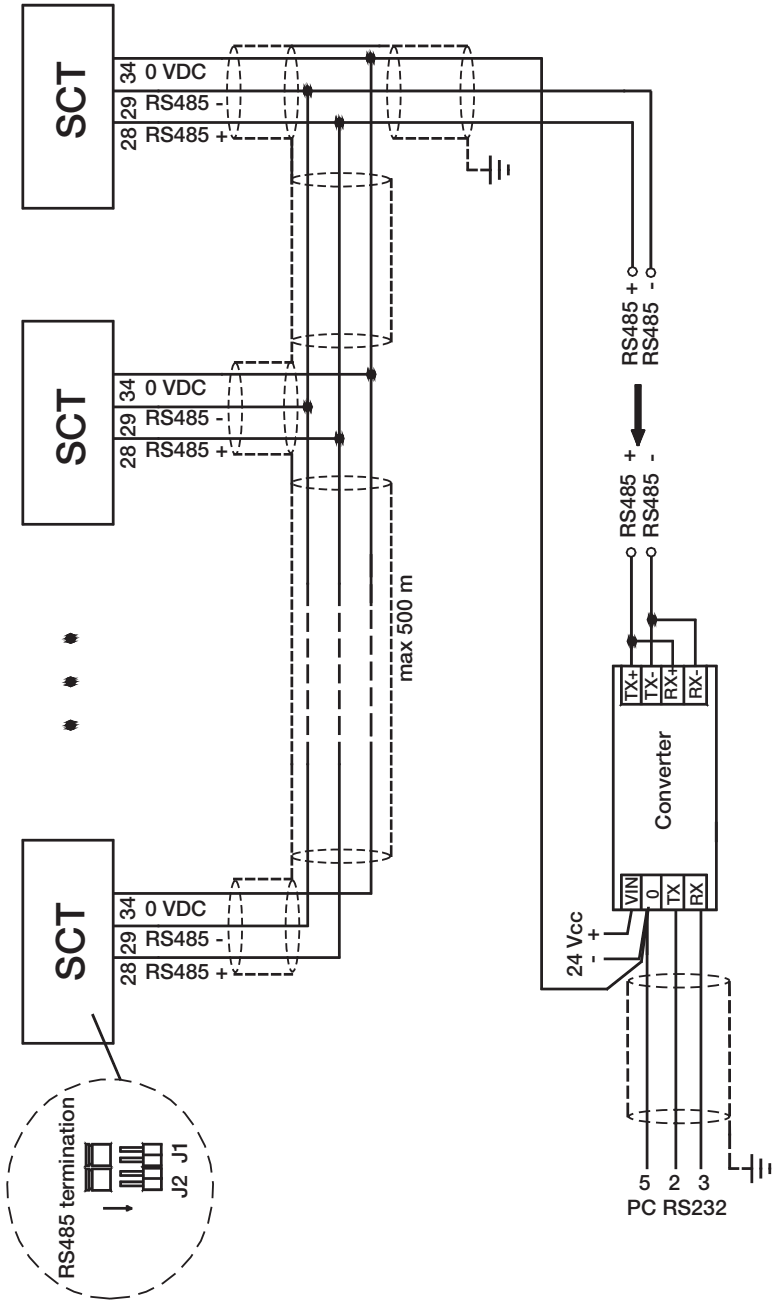

Figure 2-4. RS-485 Serial Communications



Note If the RS-485 network exceeds 100 meters in length or baud-rate over 9600 are used, close the two jumpers, called RS-485 termination, to activate two 120 ohm terminating resistors between the '+' and '-' terminals of the line, on the terminal strip of the furthest instrument. Should there be different instruments or converters, refer to the specific manuals to determine whether it is necessary to connect the above-mentioned resistors.

Direct Connection Between RS-485 And RS-232 Without Converter

Since a two-wire RS-485 output may be used directly on the RS-232 input of a PC or remote display, it is possible to implement instrument connection to an RS-232 port in the following manner:

Instrument	RS-232
RS-485 -	RXD
RS-485 +	GND



Note This type of connection allows a SINGLE instrument to be used in a ONE WAY mode.

2.6 Outputs And Inputs Configuration

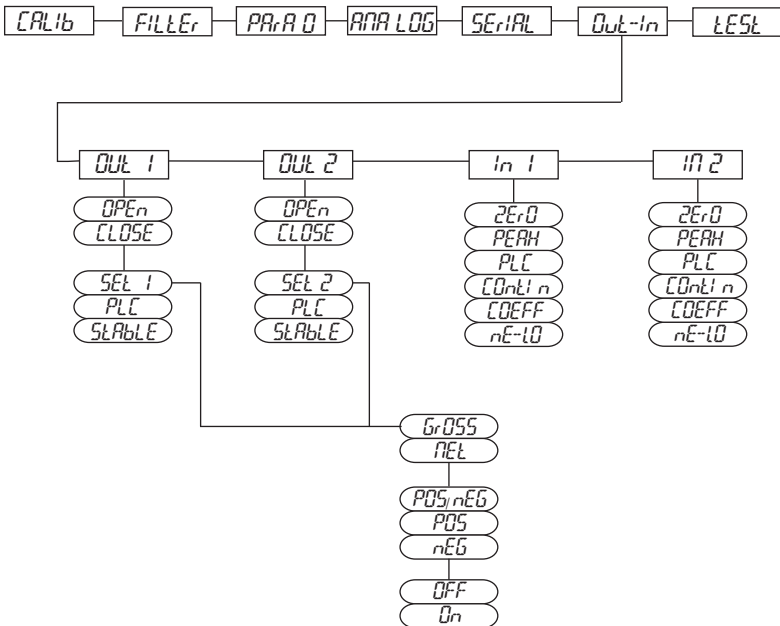

Figure 2-5. Outputs and Inputs Menu Structure













Parameter	Choices	Description
OUT 1 OUT 2	OPEN CLOSE	Normally Open: the relay is de-energized and the contact is open when the weight is lower than the programmed setpoint value; it closes when the weight is higher than or equal to the programmed setpoint value. Normally closed: the relay is energized and the contact is closed when the weight is lower than the programmed setpoint value; it opens when the weight is higher than or equal to the programmed setpoint value.
OUT 1 OUT 2	SET 1 SET 2	Number corresponds with OUT 1 or 2. The contact will switch on the basis of weight, according to setpoints (see Section 2.8 on page 29) Select: Gross (default) - the contact will switch on the basis of gross weight. or Net - the contact will switch on the basis of net weight (If the net function is not active, the contact will switch on the basis of gross weight).
	PLC	The contact will not switch on the basis of weight, but is controlled by remote protocol commands.
	STABLE	Relay switching occurs when the weight is stable.
SET 1 SET 2	POSNEG	Relay switching occurs for both positive and negative weight values.
	POS	Relay switching occurs for positive weight values only.
	NEG	Relay switching occurs for negative weight values only.
SET 1 SET 2	OFF On	Relay switching will not occur if the setpoint value is '0'. Setpoint = '0' and nodbus=posneg, relay switching occurs when the weight is '0'; the relay will switch again when the weight is different from zero, taking hysteresis into account (both for positive and for negative weights). Setpoint = '0' and nodes=pos, relay switching occurs for a weight higher than or equal to '0', the relay will switch again for values below '0', taking hysteresis into account. Setpoint = '0' and nodes=neg, relay switching occurs for a weight lower than or equal to '0', the relay will switch again for values above '0', taking hysteresis into account.

Table 2-8. Output and Input Menu

Parameter	Choices	Description
In 1 In 2	NET-GROSS [In 2 DEFRAULT]	(NET/GROSS): by closing this input for less than one second, it performs a SEMI-AUTOMATIC TARE and the display will show the net weight. To display the gross weight again, hold the NET/GROSS input closed for 3 seconds.
	TARE* (In 1 default)	By closing the input for less than one second, the weight is set to zero (see Section 3.3 Section 3.3 on page 33).
	PEEH	With the input closed the maximum weight value reached remains on display. Opening the input the current weight is displayed.
	PLC	Closing the input no operation is performed, the input status may however be read remotely by way of the communication protocol.
	CONTIN	Closing the input for less than one second the weight is transmitted via the serial connection according to the fast continuous transmission protocol one time only (only if contin is set in the item serial).
	COEFF	When the input is closed the weight is displayed based on the set coefficient (see Section 3.6 on page 30 and Section 3.7 on page 31), otherwise the weight is displayed.
* - indicates default value.		

Table 2-8. Output and Input Menu

2.7 Test









1. Press and hold , then press . [RLI b] will be displayed.
2. Press  or  until tESt is displayed, press . The currently programmed value is displayed.
3. Press  or  until desired parameter is displayed, press .
4. For In and NU-CEL, current reading is displayed, press .
For Out, press  until corresponding value of the out you want to change is flashing, press  to change the value, press .
5. Press  twice to exit set-up menu.

Parameter	Choices	Description
<i>i n</i>	N/A	Input Test - for each open input 0 is displayed, 1 is displayed when the input is closed.
<i>OUT</i>	0 * 1	Output Test - Setting 0 - the corresponding output opens. Setting 1 - the corresponding output closes.
<i>ANALOG</i>	<i>ANALOG</i>	Allows the analog signal to range between the minimum and the maximum values starting from the minimum.
	<i>mA</i>	current output test
	<i>VOLT 1</i>	voltage output test
<i>mV-CELL</i>	N/A	Millivolt Test - displays the load cell response signal in mV with four decimals.

* - indicates default value.

Table 2-9. Test Menu

2.8 Setpoints Programming

1. Press  to enter setpoints and hysteresis settings.
2. Press  or  until desired setpoint or hysteresis parameter is displayed, press .
3. Press  or  until desired value is displayed, press .
4. Press  to exit setpoints and hysteresis settings.



Note These values are set to zero if the calibration is changed significantly (see Section 2.1.1 on page 14 and Section 2.1.5 on page 16).

Parameter	Choices	Description
<i>SETP 1</i> <i>SETP 2</i>	0-Full Scale 0 *	Setpoint; relay switching occurs when the weight exceed the value set in this parameter. The type of switching is settable (see Section 2.6 on page 26).
<i>HYSLE 1</i> <i>HYSLE 2</i>	0-Full Scale 0 *	Hysteresis, value to be subtracted from the setpoint to obtain contact switching for decreasing weight. For example with a setpoint at 100 and hysteresis at 10, the switching occurs at 90 for decreasing weight.

* - indicates default value.



Table 2-10. Setpoints

2.9 Reserved For The Installer

2.9.1 Default Scale



Important *Operation must only be performed after contacting technical assistance*





1. With power off, press and hold , then power on.
Display shows *Pr 00*.
2. Press , display shows *bASE*.
3. Press , display shows *UFI t*.
4. Instrument will reboot.



Note *By confirming the displayed program, the system variables are set with default values.*

2.9.2 Program Selection - Reverse:

Scale capacity is displayed when scale is empty. As weight is added display will count down.





1. With power off, press and hold , then power on.
Display shows *Pr 00*.
2. Press , display shows *bASE*.
3. Press , display shows *rEUEr*.
4. Press , display shows *UFI t*.
5. Instrument will reboot.

By pressing  you will quit the program without introducing any changes and without deleting any of the set variables.



Note *If you do not have a specific manual for the newly set program, you can request it from technical assistance.*

2.9.3 Keypad Or Display Locking

1. Press  immediately followed by , hold them down for about 5 seconds (this operation is also possible via the MODBUS and ASCII protocols):
2. Press  or  until desired parameter is displayed, press .



Parameter	Description
<i>FrEE</i>	no lock
<i>HEy</i>	keypad lock: if active, when key is pressed the message bLOC is displayed.
<i>dI 5P</i>	Keypad and Display lock: if active, the keypad is locked and the display shows the instrument model (weight is not displayed); by pressing a key the display shows bLOC for 3 seconds.

3.0 Operation



3.1 Semi-Automatic Tare (Net/Gross)



Note *The semi-automatic tare value is lost upon instrument power-off.
The semi-automatic tare operation is not allowed if the gross weight is zero.*







1. To capture tare and weigh in net mode (SEMI-AUTOMATIC TARE), close the NET/GROSS input or press  for 3 seconds. The instrument displays the net weight (zero) and the NET LED lights up.
2. To display the gross weight again, keep the NET/GROSS input closed or press  for 3 seconds.
3. This operation can be repeated by the operator to allow the loading of several products.





Note *Press and hold  to display the gross weight temporarily. When  is released, the net weight will be displayed again.*

3.2 Preset Tare (Subtractive Tare Device)

It is possible to manually set a preset tare value to be subtracted from the display value provided that the $P-TARE \leq \text{max capacity}$.

1. Press and hold  and  to display $P-TARE$, press .
2. Press  or  until desired value is displayed, press .
3. Press  to exit $P-TARE$.
4. After setting the tare value, go back to the weight display, the display shows the net weight (subtracting the preset tare value) and the NET LED lights up to show that a tare has been entered.



Note *Press and hold  for 3 seconds to display the gross weight temporarily. When  is released, the net weight will be displayed again.*

To delete a preset tare and return to the gross weight display:

1. Press hold  for 3 seconds or keep the NET/GROSS input (if any) closed for the same length of time (3 seconds). The preset tare value is set to zero. The NET LED is turned off when the gross weight is displayed once again.



Note If a semi-automatic tare (net) is entered, it is not possible to access the enter preset tare function.

If a preset tare is entered, it is still possible to access the semiautomatic tare (net) function. The two different types of tare are added.

All the semi-automatic tare (net) and preset tare functions will be lost when the instrument is turned off.

3.3 Semi-Automatic Zero (Weight Zero-setting For Small Variations)

By closing the SEMI-AUTOMATIC ZERO input, the weight is set to zero. The zero setting will be lost when the instrument is turned off.

This function is only allowed if the weight is lower than the 0 set value (see 0 SET in Section 2.3 on page 20), otherwise the t----- alarm appears and the weight is not set to zero.

3.4 Peak

By keeping the input closed the maximum weight value reached remains displayed. Opening the input the current weight is displayed.



Note If you wish to use this input to view a sudden variation peak, set the FILTER ON THE WEIGHT (see Section 2.2) to 0.

3.5 Alarms

Display	Description
Er EEL	Load cell is not connected or is incorrectly connected; the load cell signal exceeds 39 mV; the conversion electronics (A/D converter) is malfunctioning.
Er OL	Weight display exceeds 110% of the full scale.
Er Rd	Internal instrument converter failure; check load cell connections, if necessary contact Technical Assistance.
-----	Weight exceeds the maximum weight by 9 divisions.
Er OF	Maximum displayable value exceeded (value higher than 999999 or lower than -999999).
t-----	Weight too high: zero setting not possible.
nRH-PU	This message appears in the test weight setting, in weight (span) calibration, after the fifth test weight value has been entered.
Er rOr	The value set for the parameter is beyond the permitted values; press  to quit the setting mode leaving the previous value unchanged. Examples: - a number of decimals is selected for full scale which exceeds the instrument's display potential; - value above the maximum setting value; - the weight value set in test weight verification does not match the detected mV increase.
bLDC	Lock active on menu item, keypad or display.
nOdL SP	It's not possible to display properly the number because is greater than 999999 or less than -999999.

Table 3-1. Alarm Descriptions

	ErCEL	Er OL	Er Ad	-----	Er OF	t-----
MODE						
Bit LSB	76543210 xxxxxx1	76543210 xxxx1xxx	76543210 xxxxxx1x	76543210 xxxxx1xx	76543210 On gross: xxx1xxxx On net: xx1xxxxx	The response to the zero command is a 'value not valid' error (error code 3)
Status Register MODBUS RTU						
ASCII	__O-F_	__O-L_	__O-F_	__O-L_	__O-F_	&aa#CR
RIP *	__O-F_	__O-L_	__O-F_	__O-L_	__O-F_	__O-F_
HDRIP-N	_ERCEL	_ER_OL	_ER_AD	#####	_ER_OF	O_SET
CONTIN	_ERCEL	_ER_OL	_ER_AD	^^^^^^	_ER_OF	O_SET

Table 3-2. Serial Protocols Alarms

* For RIP remote displays, if the message exceeds 5 digits the display reads -----.



Note If an alarm becomes active the relays open and the analog outputs go to the lowest possible value according to the following table:

Range	0/20mA	4/20 mA	0/5 V	0/10 V	-10/10 V	-5/5 V
Output Value	-0.2 mA	3.5 mA	-0.5 V	-0.5 V	0 V	0 V

3.6 Modbus-RTU Protocol

The MODBUS-RTU protocol enables to manage the reading and writing of the registers listed here below according to the specifications contained in the reference document for this standard Modicon PI-MBUS-300.

To select the communication with MODBUS-RTU, refer to Section 2.5 on page 23.

When specifically indicated certain data will be written directly to EEPROM type memories. This memory has a limited number of writing operations (100.000), therefore unnecessary operations at said locations must be avoided. The instrument, in any case, ensures that no writing occurs if the value to be stored is equal to the stored value.

The numerical data listed below are expressed in decimal notation, or hexadecimal notation if preceded by 0x.

Modbus-RTU Data Format

The data received and transmitted via MODBUS-RTU protocol have the following characteristics:

- 1 start bit
- 8 data bits, *least significant bit* sent first
- Instrument settable parity bit
- Instrument settable stop bit

Modbus Supported Functions

Among the commands available in the MODBUS-RTU protocol, only the following are used to manage communication with the instruments. Other commands may not be interpreted correctly and could generate errors or system shut-downs:

FUNCTIONS	DESCRIPTION
03 (0x03)	Read Holding Register (Programmable Register Reading)
16 (0x10)	Preset Multiple Registers (Write Multiple DI Register)

The interrogation frequency is linked with the preset communication rate (the instrument will stand by for at least 3 bytes before beginning to calculate a possible response to the query). The `DELAY` parameter (see Section 2.4 on page 21) allows for a further delay in the instrument response, and this directly influences the number of possible queries in the unit of time.

For additional information on this protocol, refer to the general technical specification `PI_MBUS_300`. The functions supported relative to the MODBUS standard are the `READ_HOLDING_REGISTER` and the `PRESET_MULTIPLE_REGISTERS`.

In general, the query and response to and from a slave instrument are organized as follows:

Function 3: Read Holding Registers (Programmable Register Reading)

QUERY				
Address	Function	Add. Reg. 1	No. register	2 bytes
A	0x03	0x0000	0x0002	CRC

Tot. bytes = 8

RESPONSE					
Address	Function	No. bytes	Register1	Register 2	2 bytes
A	0x03	0x04	0x0064	0x00C8	CRC

Tot. bytes = 3+2*No. registers+2

Function 16: Preset Multiple Registers (Multiple Register Writing)

QUERY							
Address	Function	Add. reg. 1	No. reg.	No. bytes	Val. reg.1	Val. reg.2	2 bytes
A	0x10	0x0000	0x0002	0x04	0x0000	0x0000	CRC

Tot. bytes = 7+2*No. registers+2

RESPONSE				
Address	Function	Add. Reg. 1	No. register	2 bytes
A	0x10	0x0000	0x0002	CRC

Tot. bytes = 8

No. REGS: Number of registers to write beginning from the address.

N° BYTES: Number of bytes transmitted as a value of the registers (2 bytes per register)

VAL. REG.: Contents of the register beginning from the first.

The answer contains the register identification modified after the command has been executed.

Communication Error Management

The communication strings are controlled by CRC (Cyclical Redundancy Check).

In case of a communication error the slave will not respond with any string. The master must allow for a time-out before response reception. If no response is received it infers that a communication error has occurred.

In the event of a string received correctly but not executable, the slave responds with an EXCEPTIONAL RESPONSE. The "FUNCTION" field is transmitted with the MSB at 1.

EXCEPTIONAL RESPONSE			
Address	Function	Code	2 bytes
A	Funct + 80h		CRC

CODE	DESCRIPTION
1	ILLEGAL FUNCTION (Function not valid or not supported)
2	ILLEGAL DATA ADDRESS (The specified data address is not available)
3	ILLEGAL DATA VALUE (The data received have no valid value)

List Of Usable Registers

The MODBUS-RTU protocol implemented on this instrument can manage a maximum of 32 registers read and written in a single query or response.

R = the register can be read only

W = the register can be written only

R/W = the register can be both read and written

H = high half of the DOUBLE WORD forming the number

L = low half of the DOUBLE WORD forming the number

REGISTER	DESCRIPTION	Saving to EEPROM	ACCESS
40001	Firmware version	-	R
40002	Type of instrument	-	R
40003	Year of Production	-	R
40004	Serial Number	-	R
40005	Active program	-	R
40006	Command Register	NO	W
40007	Status Register	-	R
40008	Gross Weight H	-	R
40009	Gross Weight L	-	R
40010	Net Weight H	-	R
40011	Net Weight L	-	R
40012	Peak Weight H	-	R
40013	Peak Weight L	-	R
40014	Divisions and Units of measure	-	R
40015	Coefficient H		R
40016	Coefficient L		R
40017	SETPOINT 1 H	Only after command '99' of the COMMAND REGISTER	R/W
40018	SETPOINT 1 L		R/W
40019	SETPOINT 2 H		R/W
40020	SETPOINT 2 L		R/W
40021	HYSTERESIS 1 H		R/W
40022	HYSTERESIS 1 L		R/W
40023	HYSTERESIS 2 H		
40024	HYSTERESIS 2 L		
40025	INPUTS	-	R
40026	OUTPUTS	NO	R/W
40037	Test weight for calibration H	Use with command '101' of the COMMAND REGISTER	R/W
40038	Test weight for calibration L		R/W
40043	Weight value corresponding to ZERO of the analog output H	Only after command '99' of the Command Register.	R/W
40044	Weight value corresponding to ZERO of the analog output L		R/W
40045	Weight value corresponding to Full Scale of the analog output H		R/W
40046	Weight value corresponding to Full Scale of the analog output L		R/W



Important

At the time of writing, the setpoints, hysteresis values are saved to the RAM and will be lost upon the next power-off; to store them permanently to the EEPROM so that they are maintained at power-on, the '99' command of the Command Register must be sent.

Weight (Span) Calibration Commands (With Test Weights)

The instrument calibration can be changed via MODBUS. To carry out this procedure, the system must be unloaded and the weight value display reset to zero with the command '100' of the Command Register. Then, a load must be placed on the system and the correct weight value must be sent to the registers 40037-40038; to save this value, send the control '101' from the Command Register. If the operation is successfully completed, the two test weight registers are set to zero.

Analog Output Setting

Write the weight in the registers "Weight value corresponding to the Full Scale of analog output H" (40045) and "Weight value corresponding to the Full Scale of analog output L" (40046) or write the weight in the registers "weight value corresponding to the ZERO of the analog output H" (40043) and "weight value corresponding to the ZERO of the analog output L" (40044). After writing the value, send the command 99 from the Command Register to save it to EEPROM memory.

Status Register	
Bit 0	Cell Error
Bit 1	AD Convertor Malfunction
Bit 2	Maximum weight exceeded by 9 divisions
Bit 3	Gross weight higher than 110% of full scale
Bit 4	Gross weight beyond 999999 or less than -999999
Bit 5	Net weight beyond 999999 or less than -999999
Bit 6	
Bit 7	Gross weight negative sign
Bit 8	Net weight negative sign
Bit 9	Peak weight negative sign
Bit 10	Net display mode
Bit 11	Weight stability
Bit 12	Weight within +/-1/4 of a division around ZERO
Bit 13	
Bit 14	
Bit 15	

Inputs Register (40025) (Read Only)	
Bit 0	INPUT 1 Status
Bit 1	INPUT 2 Status
Bit 2	
Bit 3	
Bit 4	
Bit 5	
Bit 6	
Bit 7	
Bit 8	
Bit 9	
Bit 10	
Bit 11	
Bit 12	
Bit 13	
Bit 14	
Bit 15	

Outputs Register (40026) (Read And Write)	
Bit 0	OUTPUT 1 Status
Bit 1	OUTPUT 2 Status
Bit 2	
Bit 3	
Bit 4	
Bit 5	
Bit 6	
Bit 7	
Bit 8	
Bit 9	
Bit 10	
Bit 11	
Bit 12	
Bit 13	
Bit 14	
Bit 15	



Note *The output status can be read at any time but can be set (written) only if the output has been set as or (see Section 2.6 Section 2.6 on page 26); otherwise, the outputs will be managed according to the current weight status with respect to the relevant setpoints.*

Divisions And Units Measure Registry (40014)

This register contains the current setting of the divisions (parameter dI UI S) and of the units of measure (UnI t parameter).

H Byte	L Byte
Units of measure	division

Use this register together with the Coefficient registers to calculate the value displayed by the instrument.

Least significant byte (L Byte)		
Division value	Divisor	Decimals
0	100	0
1	50	0
2	20	0
3	10	0
4	5	0
5	2	0
6	1	0
7	0.5	1
8	0.2	1
9	0.1	1
10	0.05	2
11	0.02	2
12	0.01	2
13	0.005	3
14	0.002	3
15	0.001	3
16	0.0005	4
17	0.0002	4
18	0.0001	4

Most significant byte (H Byte)		
Units of measure value	Units of measure description	Utilization of the Coefficient value with the different units of measure settings compared to the gross weight detected
0	Kilograms	Does not intervene
1	Grams	Does not intervene
2	Tons	Does not intervene
3	Pounds	Does not intervene
4	Newton	Multiples
5	Litres	Divides
6	Bar	Multiples
7	Atmspheres	Multiples
8	Pieces	Divides
9	Newton Meter	Multiples
10	Kilogram Meter	Multiples
11	Other	Multiples

Possible Command To Send To The Command Register (40006)

0	No command	17	Reserved
1		18	Reserved
2		19	
3		20	
4		21	Keypad lock
5		22	Keypad and display unlock
6		23	Keypad and display lock
7	NET display	24	
8	SEMI-AUTOMATIC ZERO	99	Save data in EEPROM
9	GROSS display	100	Zero-setting for calibration
10	Reserved	101	Test weight storage for calibration
11	Reserved		
12	Reserved		
13	Reserved		
14	Reserved		
15	Reserved		
16	Reserved	9999	Reset (reserved)

3.7 ASCII Bidirectional Protocol

The instrument replies to the requests sent from a PC/PLC.

It is possible to set a delay time for the instrument before it transmits a response (see *DELAY ?* parameter in Section 2.4 on page 21).

The following communication modes available (see Section 2.4 on page 21):

- NOdU60:
- ??Nod td:?

Data Identifiers:

\$: Beginning of a request string (36 ASCII);

& o &&: Beginning of a response string (38 ASCII);

aa: 2 characters for instrument address (48 ÷ 57 ASCII);

!: 1 character to indicate the correct reception(33 ASCII);

?: 1 character to indicate a reception error (63 ASCII);

#: 1 character to indicate an error in the command execution (23 ASCII);

ckck: 2 ASCII characters for Check-Sum (for further information, see Section on page 45);

CR: 1 character for string end (13 ASCII);

****: 1 character for separation (92 ASCII).

Setpoint Values Setting:

The PC transmits: **\$aaxxxxxyckckCR**

in which:

xxxxxx = 6 characters for the setpoint value (48 ÷ 57 ASCII);

y = A (set the value in the Setpoint 1)

y = B (set the value in the Setpoint 2)

Possible instrument responses:

- correct reception: **&&aa!\ckckCR**

- incorrect reception: **&&aa?\ckckCR**

Setpoints Storage Into EEPROM Memory:

The setpoints value relevant to the two setpoints programmed via the PC are stored to the RAM volatile memory and lost upon instrument power off. It is necessary to send a special command to save them permanently in the EEPROM memory. Please note that the number of writes allowed in the EEPROM memory is limited (about 100000).

The PC transmits: **\$aaMEMckckCR**

Possible instrument responses:

- correct reception: **&&aa!\ckckCR**

- incorrect reception: **&&aa?\ckckCR**

Reading Weight, The Setpoint And The Peak (If Present) From The Pc:

The PC transmits: **\$aajkckckCR**

in which:

j = a to read setpoint 1

j = b to read setpoint 2

j = t to read gross weight

j = n to read net weight

j = p to read the gross weight peak if the ASCII parameter is set as NOdU60; if, instead the ASCII parameter is set on NOD td the gross weight will be read. **To read the points, set the FS_tE0 equal to 50000.**

Possible instrument responses:

- correct reception: **&aaxxxxxj\ckckCR**

- incorrect reception: **&&aa?\ckckCR**

- if the peak is not configured: **&aa#CR**

in which:

xxxxxx = 6 value characters of the required weight.



Note *In case of negative weight, the first character on the left acquires the value « - » (minus sign - ASCII 45).*

In case of weight value is under -99999, the minus sign ('-') is sent alternated with the most significant figure.

Error messages:

In case of an instrument alarm for exceeding 110% of the full scale or 9 divisions above the value of the parameter NASS, the instrument sends the string:

&aassO-Lst\ckck

In case of faulty connection of the load cells or of another alarm, the instrument sends:

&aassO-Fst\ckck

in which:

s = 1 separator character (32 ASCII – space-).

Refer to Section 3.5 on page 33.

Semi-Automatic Zero (Weight Zero-Setting For Small Variations)



Important *The zero-setting will not be maintained after an instrument power-off.*

The PC transmits: **\$aaZEROckckCR**

Possible instrument responses:

- correct reception: **&&aa!\ckckCR**
- incorrect reception: **&&aa?\ckckCR**
- the current weight is over the maximum value resettable: **&aa#CR**

Switching From Gross Weight To Net Weight

The PC transmits: **\$aaNETckckCR**

Possible instrument responses:

- correct reception: **&&aa!\ckckCR**
- incorrect reception: **&&aa?\ckckCR**

Switching From Net Weight To Gross Weight

The PC transmits: **\$aaGROSSckckCR**

Possible instrument responses:

- correct reception: **&&aa!\ckckCR**
- incorrect reception: **&&aa?\ckckCR**

Reading Of Decimals And Number Of Divisions

The PC transmits: **\$aaDckckCR**

Possible instrument responses:

- correct reception: **&aaxy\ckckCR**
- incorrect reception: **&&aa?\ckckCR**

in which:

x = number of decimals

y = division value

The y field acquires the following values:

'3' for division value = 1

'4' for division value = 2

'5' for division value = 5

'6' for division value = 10

'7' for division value = 20

'8' for division value = 50

'9' for division value = 100

Zero Setting

(See Section 2.1.3)

The PC transmit the following ASCII string containing the zeroing command:

\$aazckckCR

in which:

z = weight zeroing command (122 ASCII)

Possible instrument responses:

- correct reception: **&aaxxxxxxt\ckckCR**
- incorrect reception: **&&aa?\ckckCR**
- If the instrument is not in gross weight displaying condition, the response is: **&aa#CR**

in which:

xxxxxx = 6 characters for the required weight value;

t = weight identification code (116 ASCII).

Example: Weight zero setting for instrument with address 2:

For the calibration, make sure that the scale is empty and the instrument measures a corresponding mV signal.

query: **\$02z78(Cr)** response: **&02000000t\76(Cr)**

In case of correct weight zero setting the read value (response) must be 0 (in the string "000000").



Important

The zero values are stored to the EEPROM memory, please note that the number of writes allowed is limited (about 100000). If it is necessary to reset the weight quite often, it is recommended to perform it by PC or PLC program, keeping in mind the weight deviation respect to the zero instrument.

Weight (Span) Calibration (With Test Weights)

(See Section 2.1.5)

After having performed the ZERO SETTING (see Section 2.1.3 on page 15), this function allows correct calibration to be done using test weights of known value and, if necessary, any deviations of the indicated value from the correct value to be corrected.

Load onto the weighing system a test weight, Load the test weight onto the scale, use as high a percentage of the maximum quantity to be weighed as possible. Otherwise make sure that the instrument measures a corresponding mV signal.

The PC sends the following ASCII string containing the calibration command:

\$aasxxxxxckckCR

in which:

s = calibration command (115 ASCII)

xxxxxx = 6 characters for test weight value.

Possible instrument responses:

- correct reception: **&aaxxxxxxt\ckckCR**
- incorrect reception or full scale equal to zero: **&&aa?\ckckCR**

in which:

t = gross weight identification code (116 ASCII).

xxxxxx = 6 characters to indicate the current weight value.

In case of correct calibration, the read value must be equal to test weight.

Example: Calibration for instrument with address 1 and test weight of 20000 kg:

query: **\$01s02000070(Cr)** response: **&01020000t\77(Cr)**

In case of correct calibration the read value has to be "020000".

Keypad Lock (Access Protection To The Instrument)

The PC transmits: **\$aaKEYckckCR**

Possible instrument responses:

- correct reception: **&&aa!\ckckCR**
- incorrect reception: **&&aa?\ckckCR**

Keypad Unlock

The PC transmits: **\$aaFREckckCR**

Possible instrument responses:

- correct reception: **&&aa!\ckckCR**
- incorrect reception: **&&aa?\ckckCR**

Display And Keypad Lock

The PC transmits: **\$aaKDISckckCR**

Possible instrument responses:

- correct reception: **&&aa!\ckckCR**
- incorrect reception: **&&aa?\ckckCR**

Check-Sum Calculation

The two ASCII control characters (**ckck**) are the representation of a hexadecimal digit in ASCII characters. The check digit is calculated by performing the operation XOR (exclusive or) 8-bit ASCII codes of the only part of the underlined string.

The procedure to calculate the check- sum is the following:

- Consider only the string characters highlighted with underlining;
- Calculate the EXCLUSIVE OR (XOR) of the ASCII codes for the characters;

Example:

Character	Decimal ASCII Code	Hexadecimal ASCII Code	Binary ASCII Code
0	48	30	00110000
1	49	31	00110001
t	116	74	01110100
XOR =	117	75	01110101

- The result of the XOR operation expressed in hexadecimal notation is made up of 2 hexadecimal digits (numbers from 0 to 9 or letters from A to F). In this case the hexadecimal code is 0x75.
- The check-sum inserted in the strings transmitted is made up of the 2 characters which represent the result of the XOR operation in hexadecimal notation (in our example the character " 7 " and the character " 5 ")

3.8 Fast Continuous Transmission Protocol

This protocol allows for continuous serial output at high update frequencies. Up to 80 strings per second are transmitted (with a minimum transmission rate of 9600 baud). See Section 2-4 on page 19 for limitations.

Following communication modes available (see Section 2.4 on page 21):

- NOd t: communication compatible with TX RS-485 instruments;?
- NOd td: communication compatible with TD RS-485 instruments.?
- If NOd t is set, the following string is transmitted to PC/PLC: **xxxxxxCRLF** in which:

xxxxxx = 6 ASCII characters for gross weight (48 ÷ 57 ASCII).

CR = 1 character of carriage return (13 ASCII).

LF = 1 character of line feed (10 ASCII).

In case of negative weight, the first character on the left acquires the value « - » (minus sign - ASCII 45).

In case of error or alarm, the 6 weight characters are replaced by the messages found in Section 3-1 on page 33.

- If NOd td is set, the following string is transmitted to PC/PLC: **&TzzzzzzPzzzzzz\ckckCR** in which:

& = 1 character of string start (38 ASCII).

T = reference character for gross weight.

P = reference character for gross weight.

zzzzzz = 6 ASCII characters for gross weight (48 ÷ 57 ASCII).

**** = 1 character of separation (92 ASCII).

ckck = 2 ASCII control characters calculated considering that the characters between **&** and **** are excluded. The control value is obtained by carrying out the XOR (or exclusive) operation for the 8 bit ASCII codes of the characters considered. A character expressed in hexadecimal is thus obtained, with 2 digits which may acquire values from “0” to “9” and from “A” to “F”. “**ckck**” is the ASCII code of the two hexadecimal digits.

CR = 1 character for string end (13 ASCII).

In case of negative weight, the first character on the left acquires the value « - » (minus sign - ASCII 45).

In case of error or alarm, the 6 gross weight characters are replaced by the messages found in Section 3-1 on page 33.

Fast Transmission Via External Contact: A single string can be transmitted by closing a digital input, not exceeding 1 second. (see Section 2.6 on page 26 and Section 2.4 on page 21).

3.9 Continuous Transmission Protocol To Remote Displays

Using this protocol, the instrument transmits, in continuous mode, the weight to remote displays; the communication string is transmitted 10 times per second. Following communication modes are available (see Section 2.4 on page 21):

- rl P: remote display shows the net or gross weight, depending on the remote display setting.
- Hdrl P: remote display shows the net or gross weight, depending on the remote display setting.
- Hdrl Pn:



Note See next page for more information.

The instrument sends the following string to the remote display:

&NxxxxxxLyvvvyy\ckckCR

in which:

& = 1 character of string start (38 ASCII).

N = 1 reference character for net weight. (78 ASCII).

xxxxxx = 6 ASCII characters for net or peak weight if present (48 ÷ 57 ASCII).

L = 1 reference character for gross weight (76 ASCII).

yyvvvyy = 6 ASCII characters for gross weight (48 ÷ 57 ASCII).

**** = 1 character for separation (92 ASCII).

ckck = 2 ASCII control characters calculated considering that the characters between “&” and “\” are excluded. The control value is obtained by carrying out the XOR (or exclusive) operation for the 8 bit ASCII codes of the characters considered. Character expressed in hexadecimal is thus obtained, with 2 digits which may acquire values from “0” to “9” and from “A” to “F”. “ckck” is the ASCII code of the two hexadecimal digits.

CR = 1 character for string end (13 ASCII).

In case of negative weight, the first character on the left acquires the value « - » (minus sign - ASCII 45).

If the protocol on Hdrl P has been set, the decimal point at the position shown on the instrument's display can also be transmitted. In this case, if the value exceeds 5 digits, only the 5 most significant digits are transmitted, while if the value is negative, no more than the 4 most significant digits are transmitted. In both cases, however, the decimal point shifts consistently with the value to display.

If Hdrl Pn has been set, in addition to what stated in Hdrl P protocol, the instrument transmits the prompt net every 4 seconds in the gross weight field, if the instrument is in the net mode (see Section 3.1 on page 32).

In case weight value is under -99999, the minus sign (‘-’) is sent alternated with the most significant figure.

In case of error or alarm, the 6 characters of the gross and net weight are replaced by the messages found in Section 3-1 on page 33.

3.10 Communication Examples

The numerical data below are expressed in hexadecimal notation with prefix h.

Example 1

Command for multiple writing of registers (hexadecimal command 16, h10):

Assuming that we wish to write the value 0 to the register 40017 and the value 2000 to the register 40018, the string to generate must be:

h01 h10 h00 h10 h00 h02 h04 h00 h00 h07 hD0 hF1 h0F

The instrument will respond with the string:

h01 h10 h00 h10 h00 h02 h40 h0D

Query Field Name	Hex	Response Field Name	Hex
Instrument Address	h01	Instrument Address	h01
Function	h10	Function	h10
Address of the first register H	h00	Address of the first register H	h00
Address of the first register L	h10	Address of the first register L	h10
Number of registers to send H	h00	Number of registers H	h00
Number of registers to send L	h02	Number of registers L	h02
Byte Count	h04	CRC16 H	h40
Datum 1 H	h00	CRC16 L	h0D
Datum 1 L	h00		
Datum 2 H	h07		
Datum 2 L	hD0		
CRC16 H	hF1		
CRC16 L	h0F		

Example 2

Command for multiple writing of registers (hexadecimal command 16, h10):

Assuming that we wish to write the two setpoint values on the instrument, at 2000 and 3000 respectively, the string must be sent:

h01 h10 h00 h10 h00 h04 h08 h00 h00 h07 hD0 h00 h00 h0B hB8 hB0 hA2

The instrument will respond with the string:

h01 h10 h00 h10 h00 h04 hC0 h0F

Query Field Name	Hex	Response Field Name	Hex
Instrument Address	h01	Instrument Address	h01
Function	h10	Function	h10
Address of the first register H	h00	Address of the first register H	h00
Address of the first register L	h10	Address of the first register L	h10
Number of registers to send H	h00	Number of registers H	h00
Number of registers to send L	h04	Number of registers L	h04
Byte Count	h08	CRC16 H	hC0
Datum 1 H	h00	CRC16 L	h0F
Datum 1 L	h00		
Datum 2 H	h07		
Datum 2 L	hD0		
Datum 3 H	h00		
Datum 3 L	h00		
Datum 4 H	h0B		
Datum 4 L	hB8		
CRC16 H	hB0		
CRC16 L	hA2		

Example 3

Multiple command reading for registers (hexadecimal command 3, h03):

Assuming that we wish to read the two gross weight values (in the example 4000) and net weight values (in the example 3000), reading from address 40008 to address 40011 must be performed by sending the following string:

H01 h03 h00 h07 h00 h04 hF5 hC8

The instrument will respond with the string:

H01 h03 h08 h00 h00 hF hA0 h00 h00 h0B hB8 h12 h73

Query Field Name	Hex	Response Field Name	Hex
Instrument Address	h01	Instrument Address	h01
Function	h03	Function	h03
Address of the first register H	h00	Address of the first register H	h08
Address of the first register L	h07	Address of the first register L	h00
Number of registers to send H	h00	Datum 1 H	h00
Number of registers to send L	h04	Datum 1 L	h00
CRC16 H	hF5	Datum 2 H	h0F
CRC16 L	hC8	Datum 2 L	hA0
		Datum 3 H	h00
		Datum 3 L	h00
		Datum 4 H	h0B
		Datum 4 L	hB0
		CRC16 H	h12
		CRC16 L	h73

For additional examples regarding the generation of correct control characters (CRC16) refer to the manual **Modicon PI-MBUS-300**.

SCT Weight Transmitter Limited Warranty

Rice Lake Weighing Systems (RLWS) warrants that all RLWS equipment and systems properly installed by a Distributor or Original Equipment Manufacturer (OEM) will operate per written specifications as confirmed by the Distributor/OEM and accepted by RLWS. All systems and components are warranted against defects in materials and workmanship for one year.

RLWS warrants that the equipment sold hereunder will conform to the current written specifications authorized by RLWS. RLWS warrants the equipment against faulty workmanship and defective materials. If any equipment fails to conform to these warranties, RLWS will, at its option, repair or replace such goods returned within the warranty period subject to the following conditions:

- Upon discovery by Buyer of such nonconformity, RLWS will be given prompt written notice with a detailed explanation of the alleged deficiencies.
- Individual electronic components returned to RLWS for warranty purposes must be packaged to prevent electrostatic discharge (ESD) damage in shipment. Packaging requirements are listed in a publication, *Protecting Your Components From Static Damage in Shipment*, available from RLWS Equipment Return Department.
- Examination of such equipment by RLWS confirms that the nonconformity actually exists, and was not caused by accident, misuse, neglect, alteration, improper installation, improper repair or improper testing; RLWS shall be the sole judge of all alleged non-conformities.
- Such equipment has not been modified, altered, or changed by any person other than RLWS or its duly authorized repair agents.
- RLWS will have a reasonable time to repair or replace the defective equipment. Buyer is responsible for shipping charges both ways.
- In no event will RLWS be responsible for travel time or on-location repairs, including assembly or disassembly of equipment, nor will RLWS be liable for the cost of any repairs made by others.

THESE WARRANTIES EXCLUDE ALL OTHER WARRANTIES, EXPRESSED OR IMPLIED, INCLUDING WITHOUT LIMITATION WARRANTIES OF MERCHANTABILITY OR FITNESS FOR A PARTICULAR PURPOSE. NEITHER RLWS NOR DISTRIBUTOR WILL, IN ANY EVENT, BE LIABLE FOR INCIDENTAL OR CONSEQUENTIAL DAMAGES.

RLWS AND BUYER AGREE THAT RLWS' SOLE AND EXCLUSIVE LIABILITY HEREUNDER IS LIMITED TO REPAIR OR REPLACEMENT OF SUCH GOODS. IN ACCEPTING THIS WARRANTY, THE BUYER WAIVES ANY AND ALL OTHER CLAIMS TO WARRANTY.

SHOULD THE SELLER BE OTHER THAN RLWS, THE BUYER AGREES TO LOOK ONLY TO THE SELLER FOR WARRANTY CLAIMS.

NO TERMS, CONDITIONS, UNDERSTANDING, OR AGREEMENTS PURPORTING TO MODIFY THE TERMS OF THIS WARRANTY SHALL HAVE ANY LEGAL EFFECT UNLESS MADE IN WRITING AND SIGNED BY A CORPORATE OFFICER OF RLWS AND THE BUYER.

© Rice Lake Weighing Systems, Inc. Rice Lake, WI USA. All Rights Reserved.

RICE LAKE WEIGHING SYSTEMS • 230 WEST COLEMAN STREET • RICE LAKE, WISCONSIN 54868 • USA



230 W. Coleman St. • Rice Lake, WI 54868 • USA
U.S. 800-472-6703 • Canada/Mexico 800-321-6703 • International 715-234-9171 • Europe +31 (0)26 472 1319

www.ricelake.com www.ricelake.mx www.ricelake.eu www.ricelake.co.in m.ricelake.com